



Bid Notice Abstract

Request for Quotation (RFQ)

Reference Number 10694919
Procuring Entity CARLOS HILADO MEMORIAL STATE UNIVERSITY
Title Procurement of Labor and Materials for the Repair of ETGB Roofing and Rainwater Collection Accessories - Talisay Campus
Area of Delivery Negros Occidental

Solicitation Number:	RFQ 24-094	Status	Pending
Trade Agreement:	Implementing Rules and Regulations	Associated Components	1
Procurement Mode:	Negotiated Procurement - Small Value Procurement (Sec. 53.9)	Bid Supplements	0
Classification:	Civil Works	Document Request List	0
Category:	Construction Projects	Date Published	26/03/2024
Approved Budget for the Contract:	PHP 220,000.00	Last Updated / Time	25/03/2024 10:55 AM
Delivery Period:	60 Day/s	Closing Date / Time	02/04/2024 09:00 AM
Client Agency:			
Contact Person:	Rowena De la Vida Prado Administrative Assistant II Mabini Street Talisay City Negros Occidental Philippines 6115 63-34-7120005 Ext.142 63-939-9296624 bac.sec@chmsu.edu.ph		

Description

Republic of the Philippines
 CARLOS HILADO MEMORIAL STATE UNIVERSITY
 Talisay City, Negros Occidental
 Mobile Phone Number: 0939 929 6624
 bac.sec@chmsc.edu.ph

REQUEST FOR QUOTATION
 Page 1 of 5
 Date: MARCH 21, 2024
 Quotation No. 24-094

Please quote your lowest price on the item/s listed below, stating the shortest time of delivery and submit your quotation duly signed by your representative not later than _____ in the return envelope attached herewith.

DR. ANDREW EUSEBIO S.TAN
 BAC Chairman

NOTE:

- ALL ENTRIES MUST BE TYPEWRITTEN
- DELIVERY PERIOD WITHIN 60 CALENDAR DAYS
- WARRANTY SHALL BE FOR A PERIOD OF SIX (6) MONTHS FOR SUPPLIES & MATERIALS, ONE (1) YEAR FOR EQUIPMENT, FROM DATE OF ACCEPTANCE BY THE PROCURING ENTITY

3/25/24, 10:56 AM

4. PRICE VALIDITY SHALL BE FOR A PERIOD OF _____ CALENDAR DAYS
 5. G-EPS REGISTRATION CERTIFICATE SHALL BE ATTACHED UPON SUBMISSION OF THE QUOTATION
 6. BIDDERS SHALL SUBMIT ORIGINAL BROCHURES SHOWING CERTIFICATIONS OF THE PRODUCT BEING OFFERED
- ITEM DESCRIPTION OF WORKS QTY. UNIT MATERIAL COST LABOR COST TOTAL COST
 NO. Unit Cost Material Sub-Total Cost Unit Cost Labor Sub-Total Cost
- ONE (1) LOT
 LABOR AND MATERIALS FOR THE REPAIR OF ETGB ROOFING AND RAINWATER COLLECTION ACCESSORIES - TALISAY CAMPUS

Scope of Works:

- 1.0 GENERAL REQUIREMENTS
 1.1 Mobilization and Demobilization
 1.2 Safety Occupational Hazards
 1.3 Site Clearing, Cleaning & Hauling
 1.4 Scaffolding rentals
- 2.0 STRUCTURAL WORKS
 2.1 Fabrication and installation of steel column with base plate and anchor bolts
 2.2 Surface preparation and painting of installed steel column
- 3.0 ROOFING & ROOFING ACCESSORIES WORKS
 3.1 Repair and installation of roof gutter
 3.2 Replacement of gutter downspout and connect to the existing water collector pipe
- 4.0 WINDOW LOUVERS WORKS
 4.1 Replacement of existing polycarbonate window cover into aluminum louvers (louver material provide by CHMSU)
 4.2 Installation of aluminum louvers to uncovered window frame (louver material provide by CHMSU)
- 5.0 MISCELLANEOUS WORKS

BILL OF QUANTITIES

- 1.0 GENERAL REQUIREMENTS
 1.1 Mobilization and Demobilization 1.00 lot
 1.2 Safety Occupational Hazards 1.00 lot
 1.3 Site Clearing, Cleaning & Hauling 1.00 lot
 1.4 Scaffolding rentals and safety barriers 1.00 lot
 Sub-total, 1.0 (GENERAL REQUIREMENTS)
- 2.0 STRUCTURAL WORKS
 2.1 #12- 4" x 6" x 6m I-Beam (12 lbs Medium Duty) 1.00 length
 2.2 16mmØ x 6" Expansion Bolts w/ nut and washer 10.00 pcs
 2.3 1/2" x 0.20m x 0.40m Steel Plate 1.00 sheet
 2.4 Structural levelling grout 1.00 lot
 2.5 Concrete epoxy 1.00 lot
 2.6 6013 welding rod 2.00 kilos
 2.7 4" Ø Steel Cutting Disc 5.00 pcs
 2.8 Grinding stone 4.00 pcs
 2.9 Gusset Plate 1/4" x 3" x 4" (for column and truss connections) 5.00 pcs
 2.10 Epoxy paint primer "Zinc Chromate" 1.00 gal
 2.11 Epoxy paint Top Coat "Zinc Chromate Gray" 1.00 gal
 2.12 Paint Thinner 1.00 gal
 Sub-total, 2.0 (STRUCTURAL WORKS)
- 3.0 ROOFING AND ROOFING ACCESSORIES WORKS
 3.1 Repair and installation of roof gutter 1.00 lot
 3.2 4"Ø PVC Pipes and Connections including clamp 1.00 lot
 3.3 Touch up paint and sealant 1.00 lot
 Sub-total, 3.0 (ROOFING AND ROOFING ACCESSORIES WORKS)
- 4.0 WINDOW LOUVERS WORKS
 4.1 Replacement of polycarbonate window cover and installation of aluminum steel window louvers (louvers supply by CHMSU) 1.00 lot
 4.2 Installation of aluminum louvers to uncovered window frame (louver material provide by CHMSU) 1.00 lot
 Sub-total, 4.0 (WINDOW LOUVERS WORKS)
- 5.0 MISCELLANEOUS WORKS
 5.1 FOR ALL OTHER ITEMS that are not included on listed Bill of Quantities in your Bid but tare deemed necessary for the completion of the works and the delivery of the project. 1.00 lot
 Sub-total, 5.0 (MISCELLANEOUS WORKS)
- PROJECT DURATION: 60 CALENDAR DAYS
 Note: Attach Certificate of Site Inspection
- A. TOTAL DIRECT COST
 B. CONSUMABLES:
 C. SUPERVISION AND ADMINISTRATION:
 D. TOTAL INDIRECT COST (B+C):
 E. TOTAL COST (A+D)
 F. VAT (12% OF ITEM E):
 GRAND TOTAL OF PROJECT COST:

3/25/24, 10:56 AM

*****NOTHING FOLLOWS*****

TOTAL ABC = Php 220,000.00
 PROCUREMENT OF LABOR AND MATERIALS FOR THE REPAIR OF ETGB ROOFING AND RAINWATER COLLECTION
 ACCESSORIES - TALISAY CAMPUS/J. MARQUEZ
 PR# 24-114-0222 02-22-24
 MDS 57-101-24-03 03-04-24

Line Items

Item No.	Product/Service Name	Description	Quantity	UOM	Budget (PHP)
1	ONE (1) LOT	Labor and Materials for the Repair of ETGB Roofing and Rainwater Collection Accessories	1	Lot	220,000.00

Created by Rowena De la Vida Prado
Date Created 25/03/2024

The PhilGEPS team is not responsible for any typographical errors or misinformation presented in the system. PhilGEPS only displays information provided for by its clients, and any queries regarding the postings should be directed to the contact person/s of the concerned party.

[Help](#) | [Contact Us](#) | [Sitemap](#)

© 2004-2024 DBM Procurement Service. All rights reserved.



Republic of the Philippines
CARLOS HILADO MEMORIAL STATE UNIVERSITY
 Talisay City, Negros Occidental
 Mobile Phone Number: 0939 929 6624
bac.sec@chmsc.edu.ph

REQUEST FOR QUOTATION

Page 1 of 5

Date: MARCH 21, 2024

Quotation No. 24-094

Please quote your lowest price on the item/s listed below, stating the shortest time of delivery and submit your quotation duly signed by your representative not later than _____ in the return envelope attached herewith.

DR. ANDREW EUSEBIO S.TAN
 BAC Chairman

NOTE:

1. ALL ENTRIES MUST BE TYPEWRITTEN
2. DELIVERY PERIOD WITHIN 60 CALENDAR DAYS
3. WARRANTY SHALL BE FOR A PERIOD OF SIX (6) MONTHS FOR SUPPLIES & MATERIALS, ONE (1) YEAR FOR EQUIPMENT, FROM DATE OF ACCEPTANCE BY THE PROCURING ENTITY
4. PRICE VALIDITY SHALL BE FOR A PERIOD OF _____ CALENDAR DAYS
5. G-EPS REGISTRATION CERTIFICATE SHALL BE ATTACHED UPON SUBMISSION OF THE QUOTATION
6. BIDDERS SHALL SUBMIT ORIGINAL BROCHURES SHOWING CERTIFICATIONS OF THE PRODUCT BEING OFFERED

ITEM NO.	DESCRIPTION OF WORKS	QTY.	UNIT	MATERIAL COST		LABOR COST		TOTAL COST
				Unit Cost	Material Sub-Total Cost	Unit Cost	Labor Sub-Total Cost	
	ONE (1) LOT							
	LABOR AND MATERIALS FOR THE REPAIR OF ETGB ROOFING AND RAINWATER COLLECTION ACCESSORIES - TALISAY CAMPUS							
	Scope of Works:							
1.0	GENERAL REQUIREMENTS							
1.1	Mobilization and Demobilization							
1.2	Safety Occupational Hazards							
1.3	Site Clearing, Cleaning & Hauling							
1.4	Scaffolding rentals							
2.0	STRUCTURAL WORKS							
2.1	Fabrication and installation of steel column with base plate and anchor bolts							
2.2	Surface preparation and painting of installed steel column							
3.0	ROOFING & ROOFING ACCESSORIES WORKS							
3.1	Repair and installation of roof gutter							
3.2	Replacement of gutter downspout and connect to the existing water collector pipe							
4.0	WINDOW LOUVERS WORKS							
4.1	Replacement of existing polycarbonate window cover into aluminum louvers (louver material provide by CHMSU)							
4.2	Installation of aluminum louvers to uncovered window frame (louver material provide by CHMSU)							

Date

By

Released (BAC) _____

Returned (Supplier) _____

Printed Name/Signature

Tel. No./Cellphone No.

Date



Republic of the Philippines
CARLOS HILADO MEMORIAL STATE UNIVERSITY
 Talisay City, Negros Occidental
 Mobile Phone Number: 0939 929 6624
bac.sec@chmsc.edu.ph

REQUEST FOR QUOTATION

Page 2 of 5

Date: MARCH 21, 2024
 Quotation No. 24-094

Please quote your lowest price on the item/s listed below, stating the shortest time of delivery and submit your quotation duly signed by your representative not later than _____ in the return envelope attached herewith.

DR. ANDREW EUSEBIO S.TAN
 BAC Chairman

- NOTE:
1. ALL ENTRIES MUST BE TYPEWRITTEN
 2. DELIVERY PERIOD WITHIN 60 CALENDAR DAYS
 3. WARRANTY SHALL BE FOR A PERIOD OF SIX (6) MONTHS FOR SUPPLIES & MATERIALS, ONE (1) YEAR FOR EQUIPMENT, FROM DATE OF OF ACCEPTANCE BY THE PROCURING ENTITY
 4. PRICE VALIDITY SHALL BE FOR A PERIOD OF _____ CALENDAR DAYS
 5. G-EPS REGISTRATION CERTIFICATE SHALL BE ATTACHED UPON SUBMISSION OF THE QUOTATION
 6. BIDDERS SHALL SUBMIT ORIGINAL BROCHURES SHOWING CERTIFICATIONS OF THE PRODUCT BEING OFFERED

ITEM NO.	DESCRIPTION OF WORKS	QTY.	UNIT	MATERIAL COST		LABOR COST		TOTAL COST
				Unit Cost	Material Sub-Total Cost	Unit Cost	Labor Sub-Total Cost	
5.0	MISCELLANEOUS WORKS							
	BILL OF QUANTITIES							
1.0	GENERAL REQUIREMENTS							
1.1	Mobilization and Demobilization	1.00	lot					
1.2	Safety Occupational Hazards	1.00	lot					
1.3	Site Clearing, Cleaning & Hauling	1.00	lot					
1.4	Scaffolding rentals and safety barriers	1.00	lot					
	Sub-total, 1.0 (GENERAL REQUIREMENTS)							
2.0	STRUCTURAL WORKS							
2.1	#12- 4" x 6" x 6m I-Beam (12 lbs Medium Du	1.00	length					
2.2	16mmØ x 6" Expansion Bolts w/ nut and washer	10.00	pcs					
2.3	1/2" x 0.20m x 0.40m Steel Plate	1.00	sheet					
2.4	Structural levelling grout	1.00	lot					
2.5	Concrete epoxy	1.00	lot					
2.6	6013 welding rod	2.00	kilos					
2.7	4" Ø Steel Cutting Disc	5.00	pcs					
2.8	Grinding stone	4.00	pcs					

Released (BAC) _____ Date _____ By _____
 Returned (Supplier) _____

 Printed Name/Signature

 Tel. No./Cellphone No.

 Date



Republic of the Philippines
CARLOS HILADO MEMORIAL STATE UNIVERSITY
Talisay City, Negros Occidental
Mobile Phone Number: 0939 929 6624
bac.sec@chmsc.edu.ph

REQUEST FOR QUOTATION

Page 3 of 5

Date: MARCH 21, 2024

Quotation No. 24-094

Please quote your lowest price on the item/s listed below, stating the shortest time of delivery and submit your quotation duly signed by your representative not later than _____ in the return envelope attached herewith.

DR. ANDREW EUSEBIO S.TAN
BAC Chairman

- NOTE:
1. ALL ENTRIES MUST BE TYPEWRITTEN
 2. DELIVERY PERIOD WITHIN 60 CALENDAR DAYS
 3. WARRANTY SHALL BE FOR A PERIOD OF SIX (6) MONTHS FOR SUPPLIES & MATERIALS, ONE (1) YEAR FOR EQUIPMENT, FROM DATE OF ACCEPTANCE BY THE PROCURING ENTITY
 4. PRICE VALIDITY SHALL BE FOR A PERIOD OF _____ CALENDAR DAYS
 5. G-EPS REGISTRATION CERTIFICATE SHALL BE ATTACHED UPON SUBMISSION OF THE QUOTATION
 6. BIDDERS SHALL SUBMIT ORIGINAL BROCHURES SHOWING CERTIFICATIONS OF THE PRODUCT BEING OFFERED

ITEM NO.	DESCRIPTION OF WORKS	QTY.	UNIT	MATERIAL COST		LABOR COST		TOTAL COST
				Unit Cost	Material Sub-Total Cost	Unit Cost	Labor Sub-Total Cost	
2.9	Gusset Plate 1/4" x 3" x 4" (for column and truss connections)	5.00	pcs					
2.10	Epoxy paint primer "Zinc Chromate"	1.00	gal					
2.11	Epoxy paint Top Coat "Zinc Chromate Gray"	1.00	gal					
2.12	Paint Thinner	1.00	gal					
	Sub-total, 2.0 (STRUCTURAL WORKS)							
3.0	ROOFING AND ROOFING ACCESSORIES WORKS							
3.1	Repair and installation of roof gutter	1.00	lot					
3.2	4"Ø PVC Pipes and Connections including clamp	1.00	lot					
3.3	Touch up paint and sealant	1.00	lot					
	Sub-total, 3.0 (ROOFING AND ROOFING ACCESSORIES WORKS)							
4.0	WINDOW LOUVERS WORKS							
4.1	Replacement of polycarbonate window cover and installation of aluminum steel window louvers (louvers supply by CHMSU)	1.00	lot					

Released (BAC) _____ Date _____ By _____
Returned (Supplier) _____

Printed Name/Signature

Tel. No./Cellphone No.

Date



Republic of the Philippines
CARLOS HILADO MEMORIAL STATE UNIVERSITY
 Talisay City, Negros Occidental
 Mobile Phone Number: 0939 929 6624
bac_sec@chmsc.edu.ph

REQUEST FOR QUOTATION

Page 4 of 5

Date: MARCH 21, 2024

Quotation No. 24-094

Please quote your lowest price on the item/s listed below, stating the shortest time of delivery and submit your quotation duly signed by your representative not later than _____ in the return envelope attached herewith.

DR. ANDREW EUSEBIO S.TAN
 BAC Chairman

NOTE:

1. ALL ENTRIES MUST BE TYPEWRITTEN
2. DELIVERY PERIOD WITHIN 60 CALENDAR DAYS
3. WARRANTY SHALL BE FOR A PERIOD OF SIX (6) MONTHS FOR SUPPLIES & MATERIALS, ONE (1) YEAR FOR EQUIPMENT, FROM DATE OF ACCEPTANCE BY THE PROCURING ENTITY
4. PRICE VALIDITY SHALL BE FOR A PERIOD OF _____ CALENDAR DAYS
5. G-EPS REGISTRATION CERTIFICATE SHALL BE ATTACHED UPON SUBMISSION OF THE QUOTATION
6. BIDDERS SHALL SUBMIT ORIGINAL BROCHURES SHOWING CERTIFICATIONS OF THE PRODUCT BEING OFFERED

ITEM NO.	DESCRIPTION OF WORKS	QTY.	UNIT	MATERIAL COST		LABOR COST		TOTAL COST
				Unit Cost	Material Sub-Total Cost	Unit Cost	Labor Sub-Total Cost	
4.2	Installation of aluminum louvers to uncovered window frame (louver material provide by CHMSU)	1.00	lot					
	Sub-total, 4.0 (WINDOW LOUVERS WORKS)							
5.0	MISCELLANEOUS WORKS							
5.1	FOR ALL OTHER ITEMS that are not included on listed Bill of Quantities in your Bid but are deemed necessary for the completion of the works and the delivery of the project.	1.00	lot					
	Sub-total, 5.0 (MISCELLANEOUS WORKS)							
	PROJECT DURATION: 60 CALENDAR DAYS							
	Note: Attach Certificate of Site Inspection							
	A. TOTAL DIRECT COST							
	B. CONSUMABLES:							
	C. SUPERVISION AND ADMINISTRATION:							
	D. TOTAL INDIRECT COST (B+C):							

Released (BAC) _____ Date _____ By _____
 Returned (Supplier) _____

 Printed Name/Signature

 Tel. No./Cellphone No.

 Date



Republic of the Philippines
CARLOS HILADO MEMORIAL STATE UNIVERSITY
 Talisay City, Negros Occidental
 Mobile Phone Number: 0939 929 6624
bac.sec@chmsc.edu.ph

REQUEST FOR QUOTATION

Page 5 of 5

Date: MARCH 21, 2024
 Quotation No. 24-094

Please quote your lowest price on the item/s listed below, stating the shortest time of delivery and submit your quotation duly signed by your representative not later than _____ in the return envelope attached herewith.

DR. ANDREW EUSEBIO S.TAN
 BAC Chairman

NOTE:

1. ALL ENTRIES MUST BE TYPEWRITTEN
2. DELIVERY PERIOD WITHIN 60 CALENDAR DAYS
3. WARRANTY SHALL BE FOR A PERIOD OF SIX (6) MONTHS FOR SUPPLIES & MATERIALS, ONE (1) YEAR FOR EQUIPMENT, FROM DATE OF ACCEPTANCE BY THE PROCURING ENTITY
4. PRICE VALIDITY SHALL BE FOR A PERIOD OF _____ CALENDAR DAYS
5. G-EPS REGISTRATION CERTIFICATE SHALL BE ATTACHED UPON SUBMISSION OF THE QUOTATION
6. BIDDERS SHALL SUBMIT ORIGINAL BROCHURES SHOWING CERTIFICATIONS OF THE PRODUCT BEING OFFERED

ITEM NO.	DESCRIPTION OF WORKS	QTY.	UNIT	MATERIAL COST		LABOR COST		TOTAL COST
				Unit Cost	Material Sub-Total Cost	Unit Cost	Labor Sub-Total Cost	
	E. TOTAL COST (A+D)							
	F. VAT (12% OF ITEM E):							
	GRAND TOTAL OF PROJECT COST:							
	*****NOTHING FOLLOWS*****							
	TOTAL ABC = Php 220,000.00							
	PROCUREMENT OF LABOR AND MATERIALS FOR THE REPAIR OF ETGB ROOFING AND RAINWATER COLLECTION ACCESSORIES - TALISAY CAMPUS/J. MARQUEZ							
	PR# 24-114-0222 02-22-24							
	MDS 57-101-24-03 03-04-24							

Released (BAC) _____ Date _____
 Returned (Supplier) _____ By _____

 Printed Name/Signature

 Tel. No./Cellphone No.

 Date

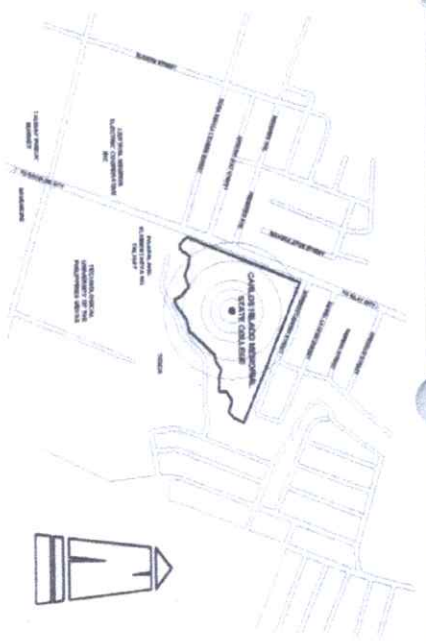

VICINITY MAP
SCALE
NDTS

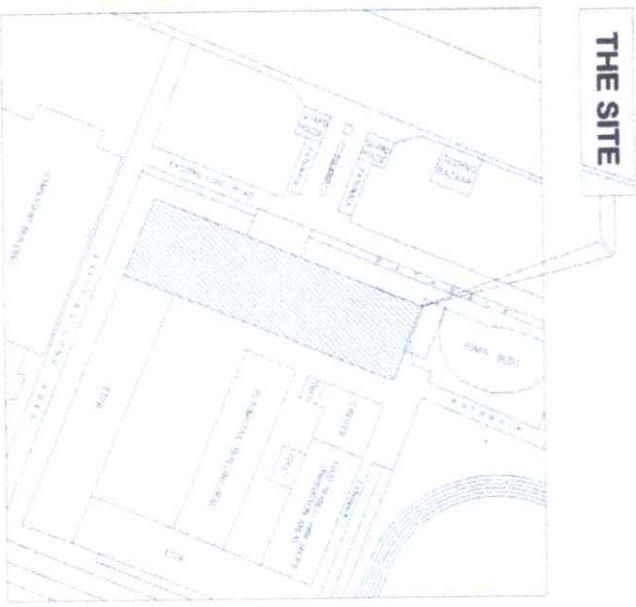

THE SITE

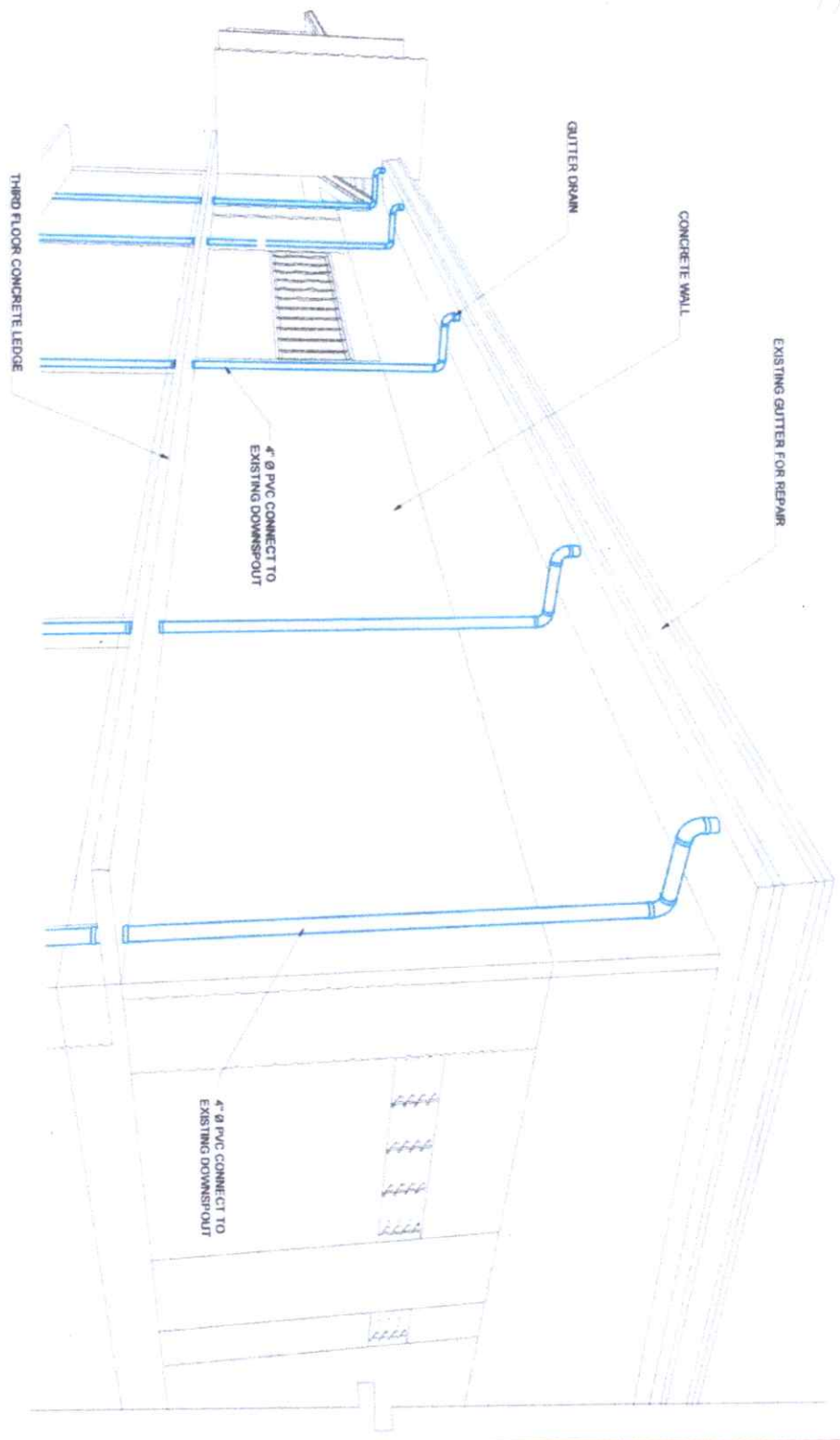

SITE DEVELOPMENT PLAN
SCALE
NDTS

ISOMETRIC DRAWING
SCALE
NDTS

 Republic of the Philippines CARLOS RAMOS MEMORIAL STATE UNIVERSITY Negros Occidental OFFICE OF THE MUNICIPAL PLANNING AND MANAGEMENT	PROJECT TITLE: REPAIR OF EGGS HOODING AND RAINWATER COLLECTION ACCESSORIES	PREPARED BY: ARNEL R. LATURNAS UNIVERSITY GRADUATE	CHECKED BY: ENGR. GIAN M. DELA CRUZ JR. PROJECT ENGINEER	DESIGNED BY: ENGR. JUN-JUN J. MORALES DIRECTOR FROM	APPROVED BY: ROSALINDA S. VIVILLA, JD VICE PRESIDENT FOR ADMINISTRATION AND FINANCE	APPROVED BY: NORBERTO J. MANUELABANAN, Ph.D SUC PRESIDENT III	SHEET NO: A	PAGE NO: 1
	DATE: FEB 13 2024		DATE: FEB 13 2024		DATE: FEB 13 2024		DATE: FEB 13 2024	

2/13

LEGEND :

- WINDOW OPENING LOCATION
- ADDITIONAL COLUMN

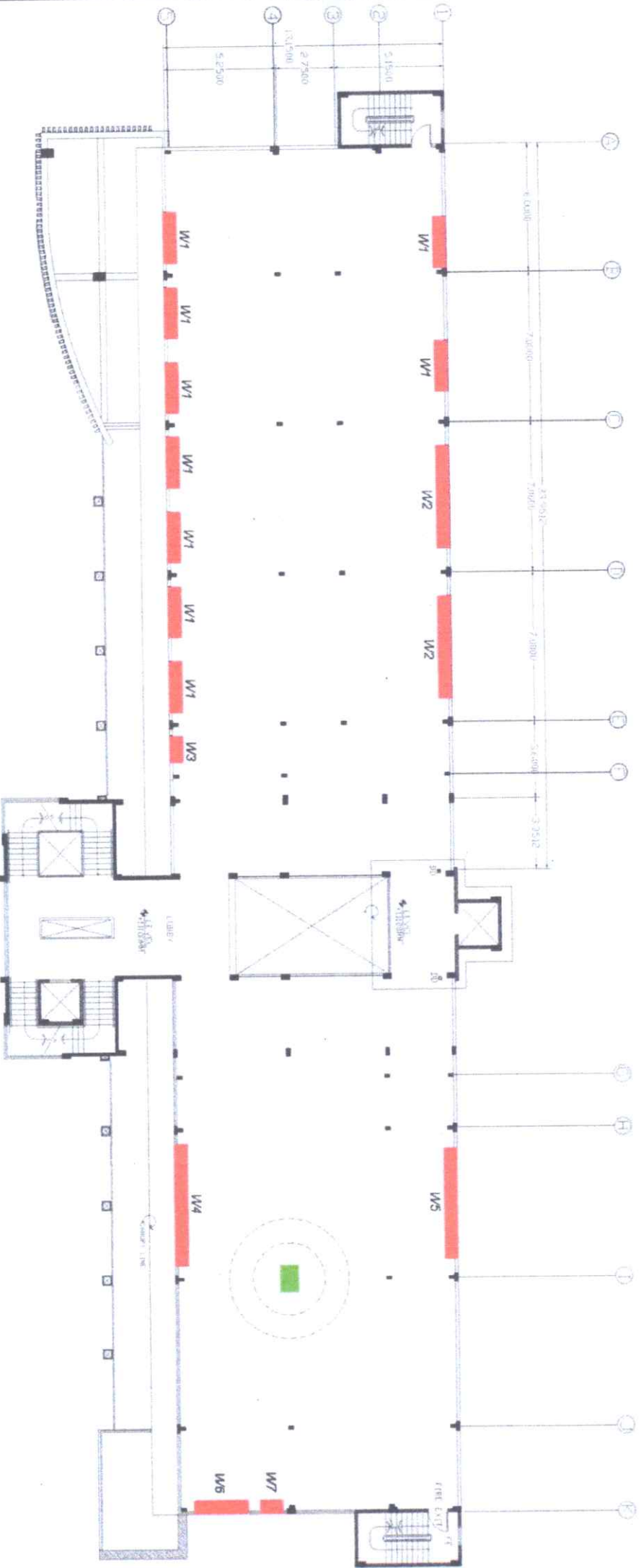

GREEN BUILDING THIRD FLOOR ROOF PLAN
SCALE

NOTS

 <p>Republic of the Philippines NATIONAL CENTER OF THE PHILIPPINES STATE UNIVERSITY Naga City, Camarines Sur</p>	<p>PROJECT TITLE: REPAIR OF EGG ROOFING AND RAINFALL COLLECTION ACCESSORIES</p>	<p>PREPARED BY: ARNEL K. LATINAS UNIVERSITY DRAFTSMAN</p>	<p>CHECKER: ENGR. GABRIEL S. LACOR UNIVERSITY DRAFTSMAN</p>	<p>ENGR. JUN-JUN J. MARQUEZ DIRECTOR</p>	<p>ROSALINDA S. TUVILA, JD SCT PRESIDENT FOR ADMINISTRATION AND FINANCE</p>	<p>APPROVED BY: NORBERTO P. MANGALAMAN, Ph.D. SCT PRESIDENT III</p>	<p>SHEET NO.: A PAGE NO.: 2</p>
---	--	--	--	---	--	--	---

LEGEND :

- DOWNSPOUT
- ROOF GUTTER

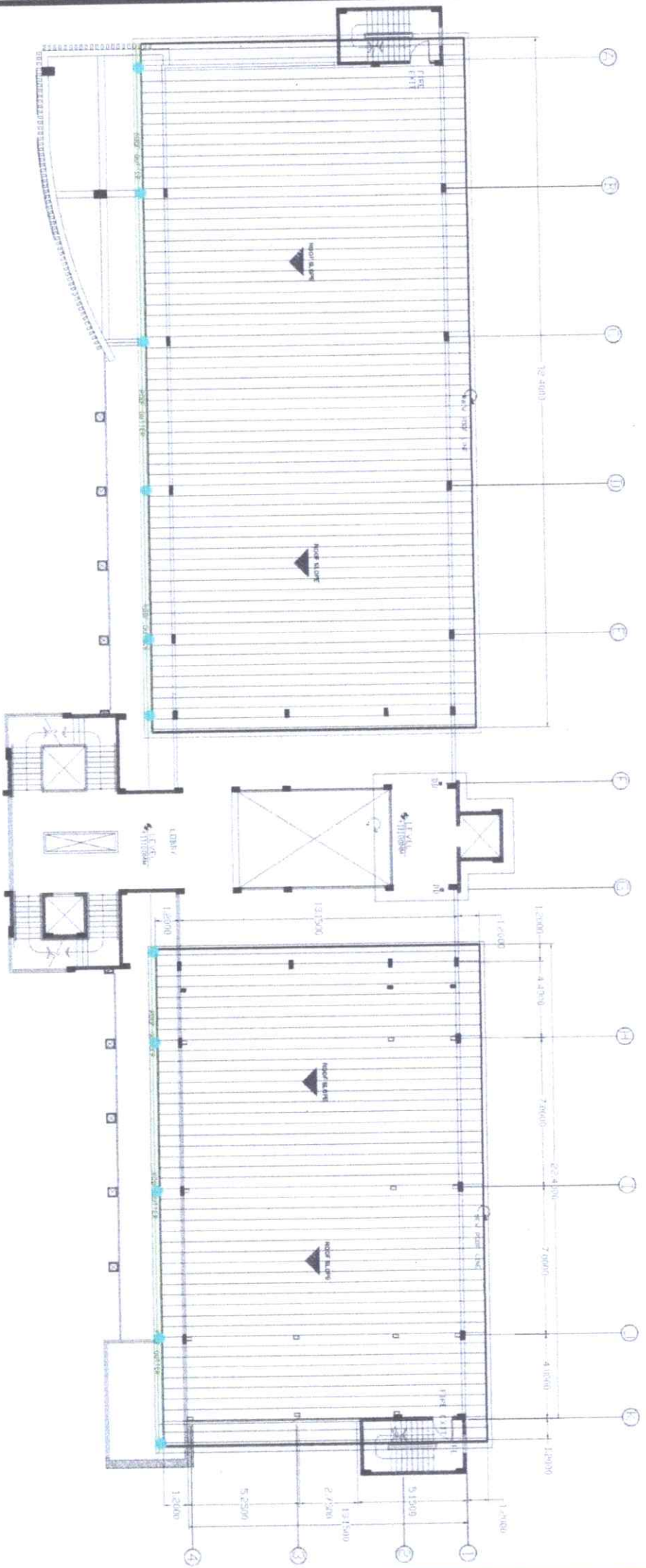

**ROOF PLAN
DOWNSPOUT LOCATION PLAN**

SCALE

NDTS

 <p>Republic of the Philippines NATIONAL WATER RESEARCH INSTITUTE Department of Water Resources</p>		<p>PROJECT TITLE: REPAIR OF EIGA ROOFING AND RAINWATER COLLECTION ACCESSORIES</p>		<p>PREPARED BY: ARNEL R. LATURNAS UNIVERSITY OF SANTO TOMAS</p>		<p>CHECKED BY: ENGR. GABRIEL A. SANDOVAL JR. REGISTERED PROFESSIONAL ENGINEER</p>		<p>APPROVED BY: ROSAWANDA S. TUVILA, ID VICE PRESIDENT FOR ADMINISTRATION AND FINANCE</p>		<p>APPROVED BY: NOBBERTO P. MARIQUILANAN, Ph.D. VICE PRESIDENT</p>	
<p>PROJECT LOCATION: CIMAU MAIN CAMPUS</p>		<p>CHECKED BY: ENGR. GABRIEL A. SANDOVAL JR. REGISTERED PROFESSIONAL ENGINEER</p>		<p>APPROVED BY: ROSAWANDA S. TUVILA, ID VICE PRESIDENT FOR ADMINISTRATION AND FINANCE</p>		<p>APPROVED BY: NOBBERTO P. MARIQUILANAN, Ph.D. VICE PRESIDENT</p>		<p>SHEET NO.: A</p>		<p>PAGE NO.: 3</p>	

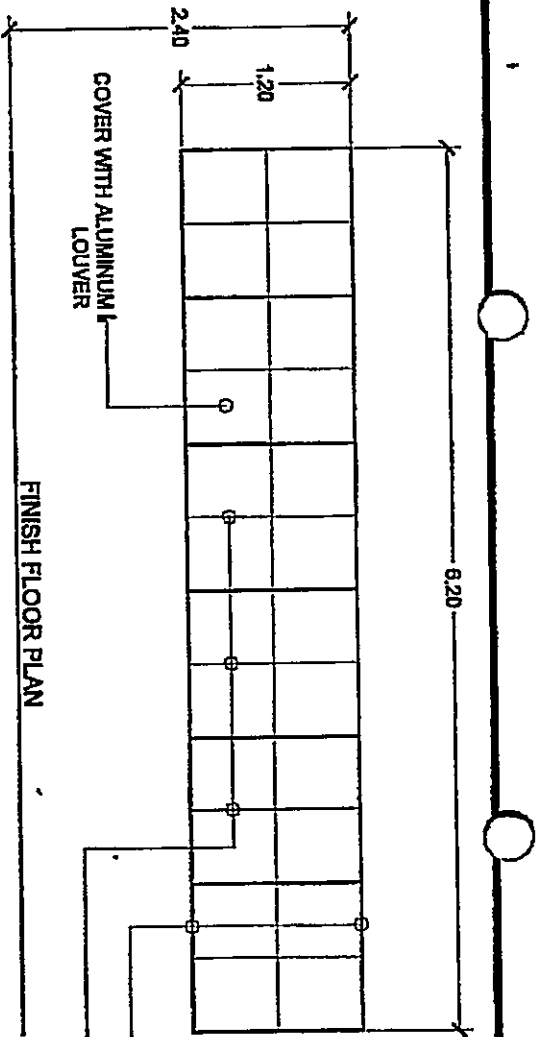

W4
NO OF UNITS 1

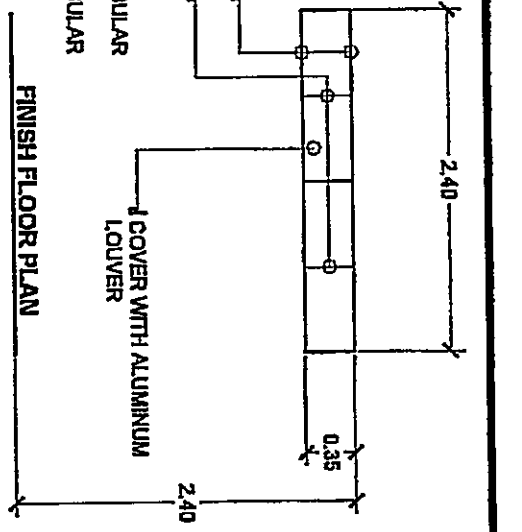

W6
NO OF UNITS 1

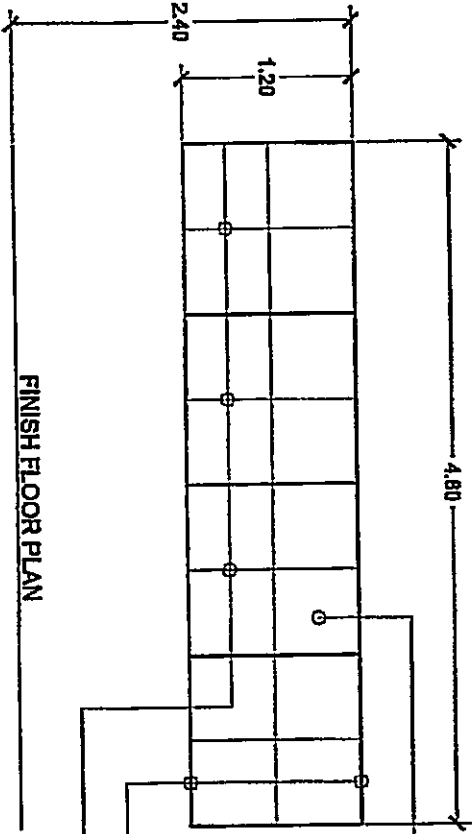

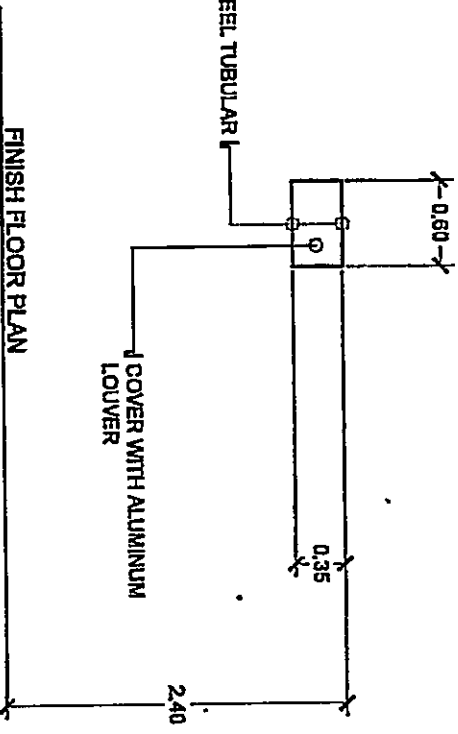

W5
NO OF UNITS 1



W7
NO OF UNITS 1

WINDOW OPENING DETAIL
SCALE NDTS

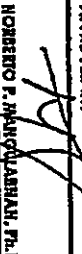
 Republic of the Philippines CHINA MALIBON NATIONAL STATE UNIVERSITY Iloilo, Iloilo City		PROJECT TITLE REPAIR OF DIGA ROOFING AND DRAINAGE COLLECTION ACCESSORIES PROJECT LOCATION: CHINA MAIN CAMPUS		PREPARED BY: ANNE L. LARINAS UNIVERSITY DESIGNER		CHECKED BY:  ENGR. J. J. JORDAN M. PROJECT ARCHITECT		DESIGNED BY: ENGR. J. J. JORDAN M. ARCHITECT		APPROVED BY:  HONORABLE F. MANUJALAN, Ph.D. VICE PRESIDENT FOR ADMINISTRATION AND FINANCE SVP PRESIDENT		SHEET NO.: A		PAGE NO.: 5	
--	--	--	--	---	--	--	--	---	--	---	--	------------------------	--	-----------------------	--

LEGEND :

- 4" x 6" I - BEAM COLUMN
- METAL PLATE
- EXPANSION BOLT

PLAN

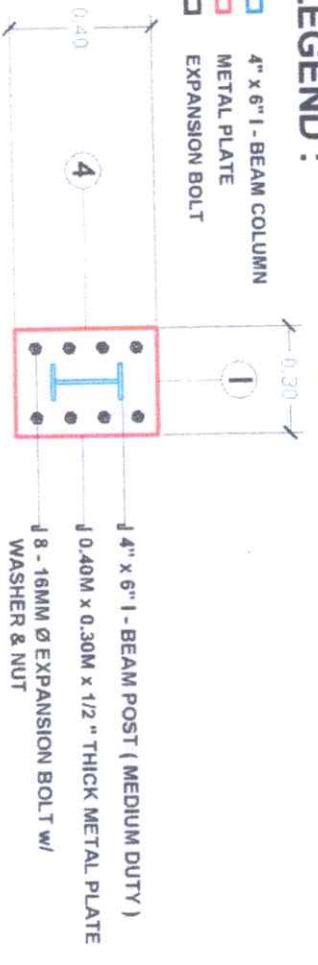

LEGEND :

- EXISTING GUTTER
- GUTTER FRAME

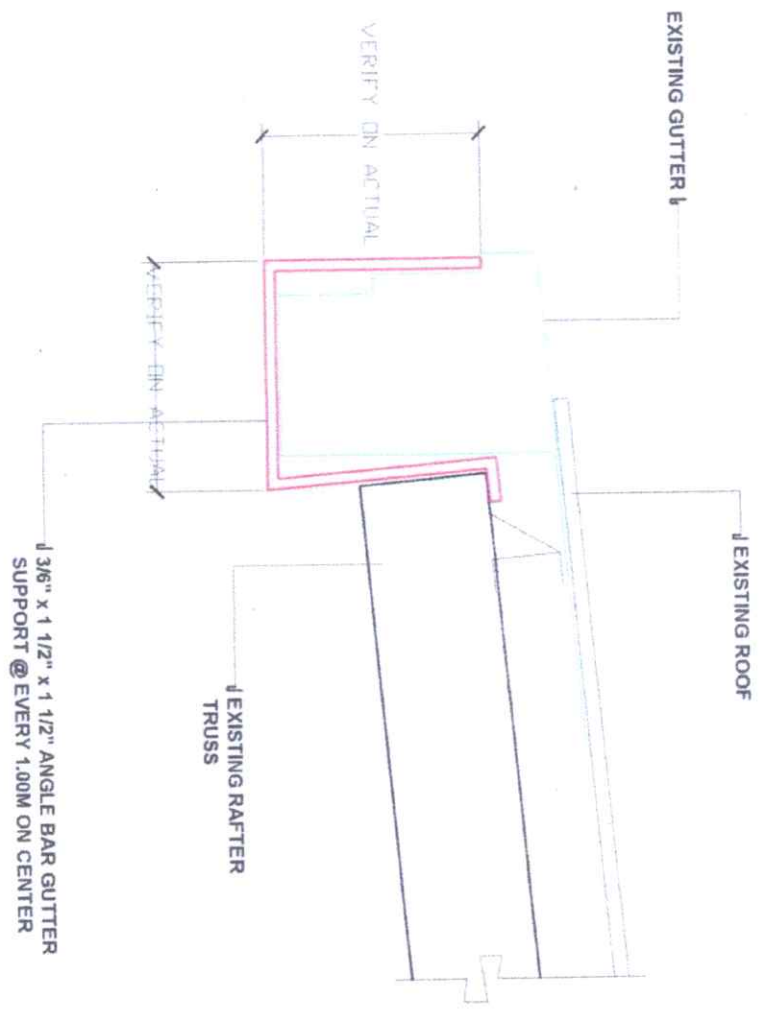

SECTION

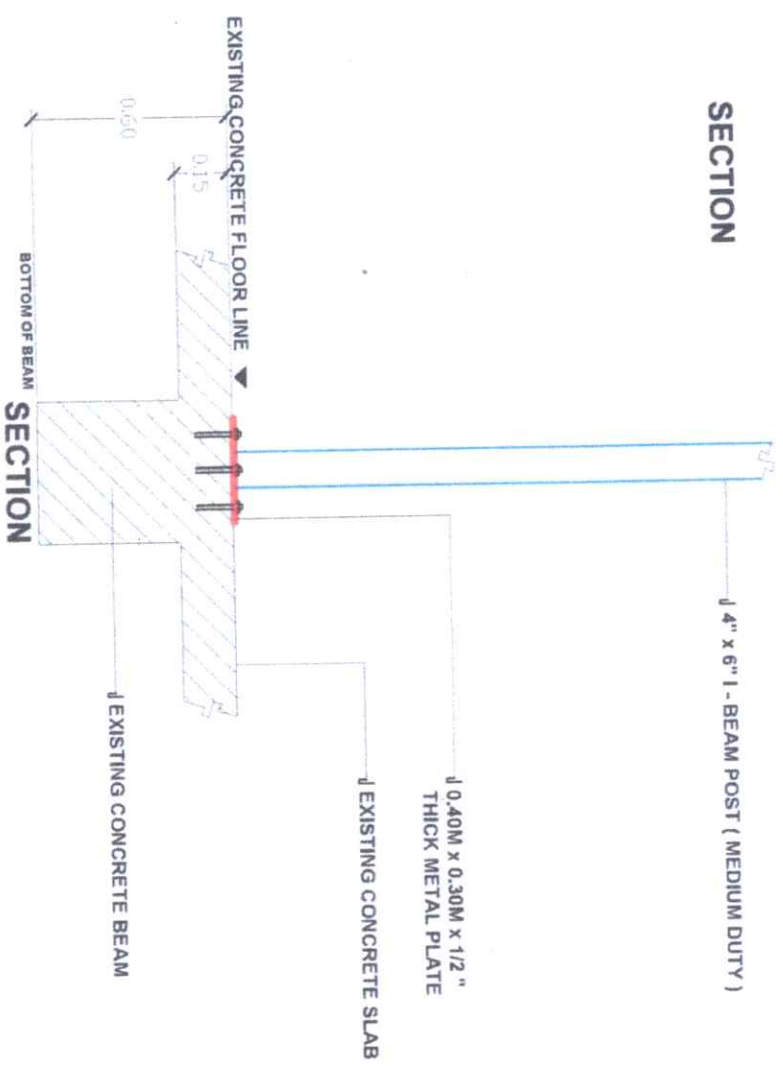

STEEL COLUMN DETAIL

SCALE

1:20M

GUTTER FRAME DETAIL

SCALE

1:20M

PROJECT TITLE

REPAIR OF EIGB ROOFING AND RAINWATER COLLECTION ACCESSORIES

PREPARED BY:

ARNEL E. LATURNAS
UNIVERSITY DRAFTSMAN

CHECKED BY:

ENGR. DONALD O. CHOLDO JR.
DIRECTOR FROM

APPROVED BY:

ENGR. JUN J. MARQUEZ
DIRECTOR FROM

APPROVED BY:

ROSALENE S. TUWILLA, D
VICE PRESIDENT FOR ADMINISTRATION AND FINANCE

APPROVED BY:

HORBERTO P. MANGUABANAN, Ph. D
SUC PRESIDENT

SHEET NO.:

A

PAGE NO.:

6



Republic of the Philippines
CAROLINO MEMORIAL STATE UNIVERSITY
Negros Occidental

DIRECTOR OF THE ARCHITECTURAL SERVICES AND MANAGEMENT



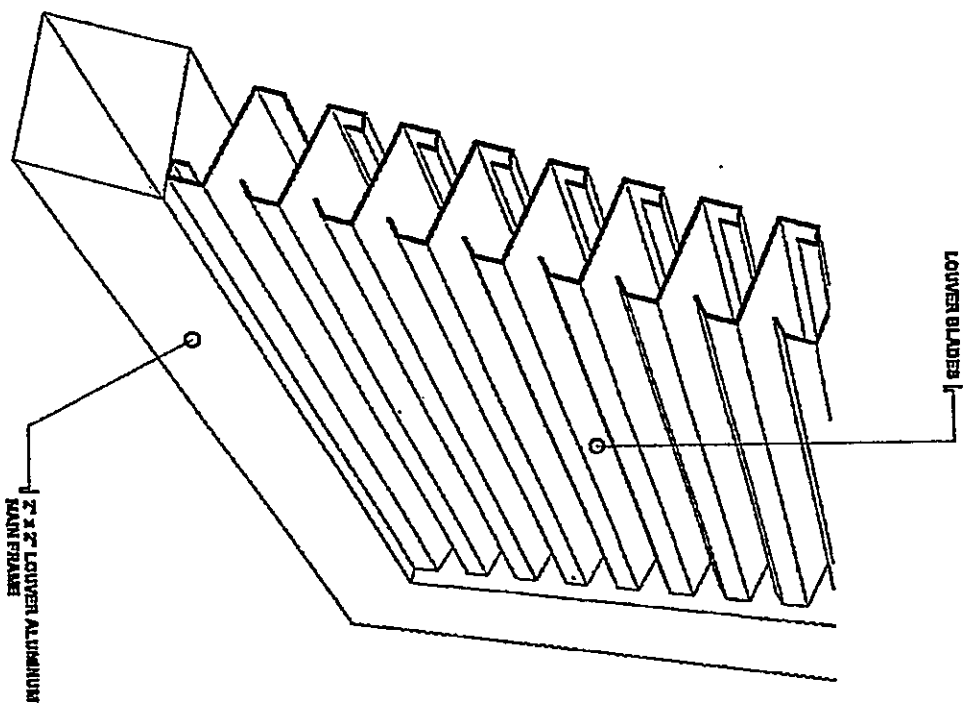
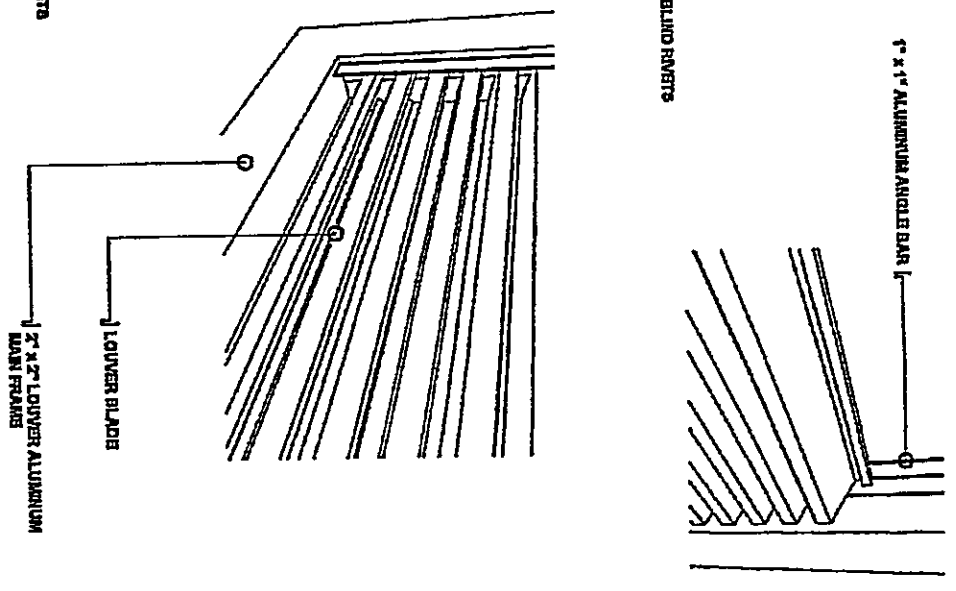
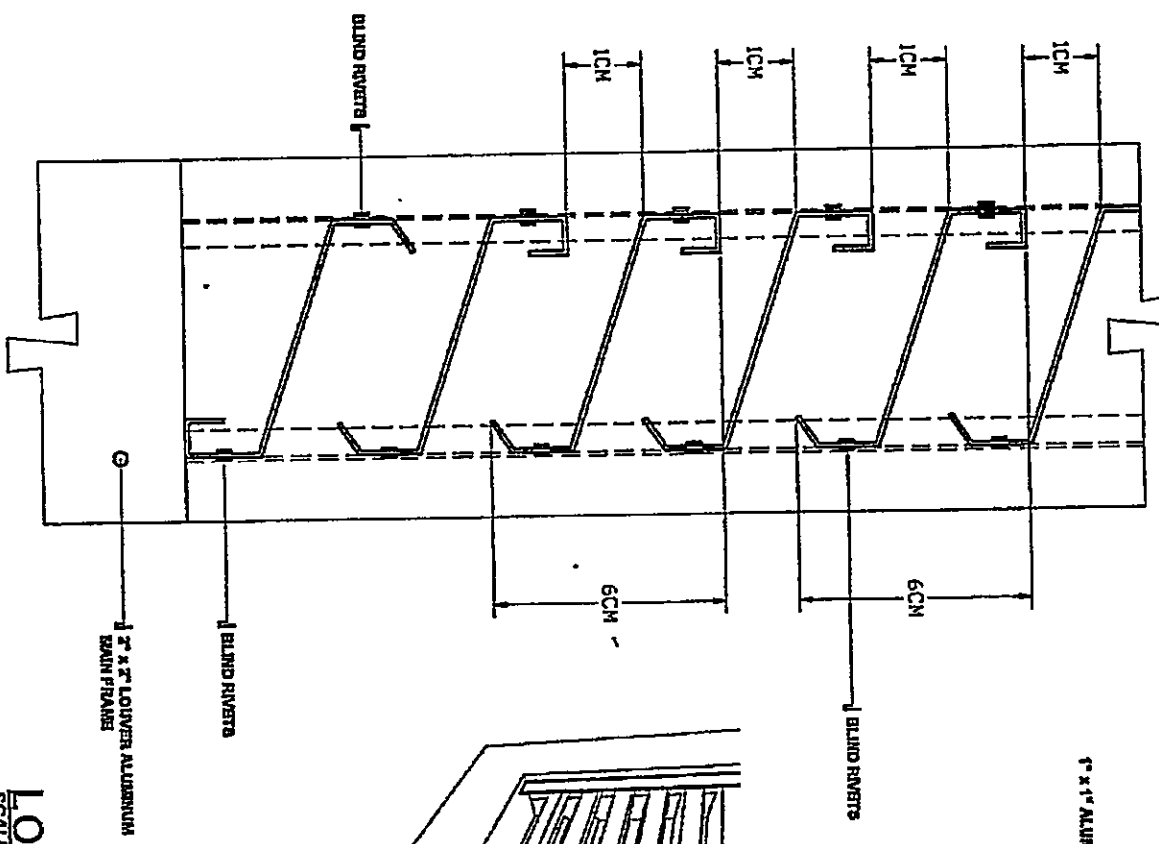

PROJECT LOCATION: CHAVIS MAIN CAMPUS

LOUVER BLADES SPACING DETAIL



LOUVER BLADE DETAIL

SCALE NOTS

 Republic of the Philippines CIVIL ENGINEERING BOARD CIVIL ENGINEERS HONORABLE OFFICERS	PROJECT TITLE	PREPARED BY:	CHECKED BY:	ENGINEER-IN-CHARGE:	APPROVED BY:	SHEET NO.:	PAGE NO.:
	REPAIR OF EIGN HOODING AND RAINWATER COLLECTION ACCESSORIES PROJECT LOCATION: CAGAYAN MAIN CAUARY	ARNELA M. LATURRAS CIVIL ENGINEER	 ARNELA M. LATURRAS CIVIL ENGINEER	 ENGR. JIM J. MASQUE CIVIL ENGINEER	 ROSALINDA S. TIVILA VICE PRESIDENT FOR ADMINISTRATION AND FINANCE	 ROBERTO P. MANGUYARAN, P.E.D VICE PRESIDENT	A